

# VANGUARD NEWS

Established 1967

NEWSLETTER SPRING 2010

## 2010 MARKS 43 YEAR MILESTONE FOR VANGUARD ROOFING AND CONSTRUCTION

Founded by Jim Staats of South Bethlehem, New York - VANGUARD ROOFING & Construction Company celebrates 43 years of continuous service.

Staats started his company not long after a three year stint in the Army and credits his step-father Harry Schuff for taking the time to teach him the building and roofing trades through the summers of his youth. Schuff, a building and roofing contractor had constructed over 50 custom homes and taught Staats everything from fine cabinet making to slate and tin roofing. The Schuff Brothers - Harry and Chet, had personally slated over half the houses in West Albany, New York, in the early 1940's and '50's.

### INSIDE!

- \* SLATE - The Original "Green" Roof
- \* TERNE & COPPER - The correct choice for low pitch roofing restoration.
- \* ILLEGAL ALIENS - Taking Roofing Jobs?
- \* TAX CREDITS For Roofing.
- \* BUILT-IN GUTTERS - Restoring To Original

Slate &  
Copper

Historical  
Restoration

Terne  
"Tin Roofs"

Remember  
In 1967.....



Schuff was a fine craftsman and held the training apprentice Staats to a high standard - lessons that he would carry to his own business which he started in 1967. Jim Staats opened his business with the motto -

***"Where Superior  
Workmanship Still Means Something"***

A creed that he still believes in strongly and expects of all his workers.

A New House  
was \$14,425.00

A New Car was  
\$2,724.00

Gasoline was  
33 cents per gallon

Average Income  
was \$7,305.00

## SLATE THE ORIGINAL “GREEN ROOF”



While builders and architects have been rushing to innovate designs to meet environmental demands from “green” conscious home buyers, a completely natural roofing material - slate, has been servicing American houses for over 150 years. A typical residential home roofed with asphalt shingles (that are petroleum based) will usually be replaced 4-5 times over a 100 years - the average life span of a slate roof. This means that a small 2000 sq’ roof (20 squares) or about 14 tons of old shingles would have to be removed over a 100 year period and hauled to a landfill site, which most are charging \$100.00 per ton plus trucking. Add to that the high cost of labor and materials, and indexing inflation, that same roof would probably cost over \$200,000.00.

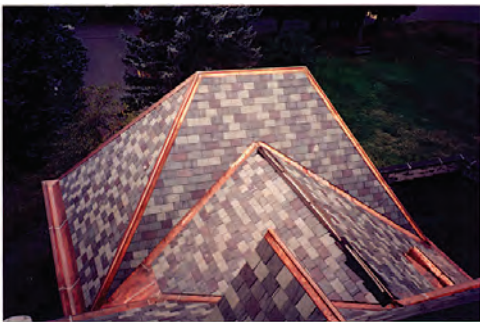

[Bird's-eye view of slate and copper. Built-in gutters; Convent of the Sacred Heart, Albany, NY.]

Since slate is natural sedimentary rock, after 100 years of use it can be deposited in a clean landfill for free, without any harm to the soil or air. Today, that same 20 sq’ roof with installed slate would cost between \$25 - 35,000; initially a larger investment - but by far the least expensive for long term, and the most beautiful aesthetically I might add.

- Jim Staats

**For More Information  
On Slate Roofs See:  
[www.evergreenslate.com](http://www.evergreenslate.com)**



[Flat locked & soldered copper was selected for the low pitched roofs on this 1894 Queen Anne Victorian, while center small turrets were formed into standing seam.]

## TERNE & COPPER

Perhaps you own one, or have certainly seen those beautiful porches wrapping around the old homes. Some of these porches are simple entrance structures while others are grand wrap-around with portico.

Before air conditioning, families and friends would relax in the fresh air with iced tea or lemonade, shaded from

***“Most roofing companies lack expertise of installing terne roofs and have little regard and appreciation for the carpentry work that is needed to make a proper restoration”***

---

the sun or enjoy their favorite dessert while the moon was coming up.

These roofs are generally low pitch and were never intended to have shingles or slate that are appropriate for steeper pitches.

From the mid 1800’s and earlier, terne - commonly referred to as “tin”, would be formed into interlocking sheets (usually 14” x 20”) and soldered. These roofs were then primed and painted, and with proper maintenance many have been in service for over 100 years!

## *...Copper ~ From Ancient Architecture To Modern Solutions...*

Its timeless beauty dates back to the Egyptian, Greek and Roman times of Pagan architecture through the middle ages of sky piercing churches. From the Renaissance Era and the XVII and XVIII centuries of French and English structures to early American years of revolutionary concepts, copper endures in distinctive designs.

With the exception of gold, it is the only primary metal that possesses color, a rich natural red gold that eventually cloaks itself with a soft green patina. For centuries, sheet metal craftsmen have been following the early designs of standing and flat seam copper roofing, and Vanguard Roofing prides itself in carrying on a great tradition.



**[Ornate Copper Entrance Porch Roof With Built-in Gutters On An Old Middleburg Colonial]**

The durability of copper is unmatched which makes it an economical choice. It requires neither painting nor protective maintenance making its first cost its last. 50, 100 years and more is not uncommon for the lasting beauty of copper. "There is an increased interest in the uses of copper, not only for commercial and residential restorations, but newer homes as well", says Jim Staats of Vanguard Roofing. "We have many homeowners coming to us with low pitched roofs on additions, dormers and porches that have failed more than once with the typical roll roofing that wouldn't last more than 10 to 12 years, even if it didn't leak. Often times, damages are extensive to the substructure and ceilings beneath, making the cost of the cheap roofing more expensive than if it were done in copper in the first place. "Typically, the flat seam copper roofing is small 18" x 24" pans, interlocked with each seam being soldered together so the finish is one impenetrable surface to the elements. Copper can be formed to contour built-in gutters and valleys as well as vertically under siding to prevent ice and water from entering."

---

***"With the exception of gold, it is the only primary metal that possesses color.  
A rich natural red gold that eventually cloaks itself with a soft green patina."***

---

Vanguard also fabricates custom gutters of copper with skirts that extend on to the roof so that shingles and slates will overhang without any chance for water to enter the cornices or drip behind the gutter.

"We also do a lot of bay windows, smaller entrance roofs and snowslides", says Staats. "The popular design for these steeper roofs is the traditional "standing seam" which can be used wherever the roof has steep pitches.

# RESTORATION OF BUILT-IN GUTTERS

For many older homes, roofs were designed with a built-in gutter system to drain water to the ground. Both lower and upper roof sections would often be framed with a trough that was pitched around the perimeter and yet concealed from the curb;

BEFORE



[BEFORE - Years of neglect led to spanning the tin roof and built-in gutter on this 1880 Folk Victorian.]

leading to the stately beauty of ornate cornices.

The troughs were then lined with interlocking flat seam terne or copper and soldered to prevent leaking.

*“Soldering of tin and copper is fast becoming a lost art, but necessary to correctly restore a tin or copper gutter lining”*

AFTER



[AFTER - Vanguard worked with new owners to restore the roof and porch back to original. The tin roof is made of 14" x 20" sheets of terne, interlocked and soldered.]

## Porch Trouble Spots

Wherever water can enter and collect will eventually become a site for decay.

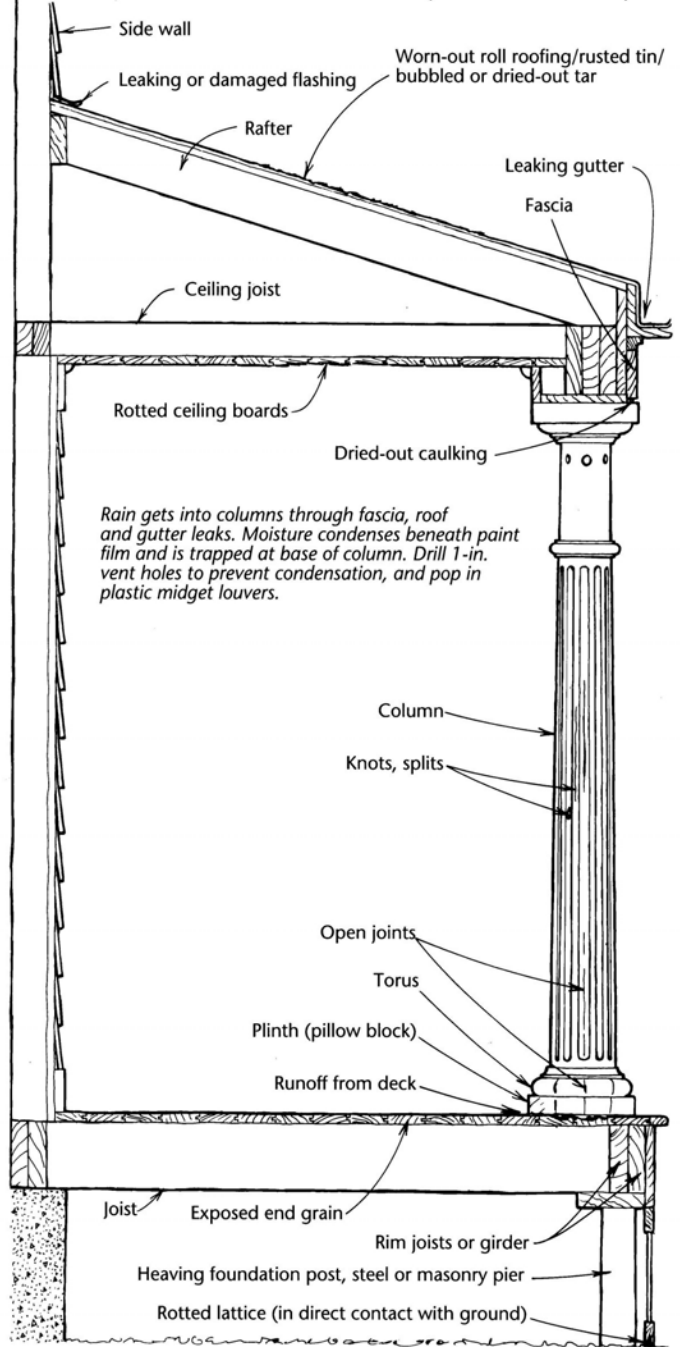

\* Courtesy of The Taunton Press, Inc. (c) 1998. “Renovating Old Houses” by George Nash.

## OUR MISSION

*“To complete each job in a timely manner; giving our customers superior workmanship and quality materials for a fair price through training, experience, and teamwork.”*



[James S. Staats, owner and CEO of Vanguard Roofing and Construction Co.]



[24" Taper Sawn Cedar Wood Shingles were selected for this 1900 turn of the century stone well house]

## TAX CREDITS FOR ENERGY EFFICIENT ROOFS

The American Recovery and Reinvestment Act of 2009 ARRC provides up to \$1,500 tax credit or 30% of material costs for Energy Star rated roofing products. Homeowners may use the tax credits for their principal residence up until December 31, 2010. If the roofing materials don't add up to the \$1,500 credit, other improvements in energy efficient window and door upgrades, as well as insulation can be used. Certain manufacturers of white asphalt/fiberglass shingles and metal roofings can also qualify.

For more information see:  
[www.energystar.gov](http://www.energystar.gov)



[GAF Ultra Timberline Architectural Shingles and copper flashings were used for Slingerlands, NY home]

## SLATE REPAIRS?

Don't be persuaded by rip-off roofers into removing a slate roof that may just need a few repairs and TLC! We have slate roofs that were repaired 25-30 years ago, that are still going strong!

## *Terne & Copper Continued.....*

Because of its lightweight and malleable qualities, terne can be formed to various designs of older historic homes.

While terne may be a restoration choice for older low-pitched roofs, copper may be used in either a flat locked or standing seam as well, eliminating the need for painting.

***“Most roofing companies lack the expertise of installing terne roofs and have little regard and appreciation for the carpentry work that is needed to make a proper restoration”***



***[New Terne Roof, Locked And Soldered 14 X 20" Sheets, (1840) Thompson Bank. Old Sturbridge Village, MA]***

*Dear Jim -*

*I wanted to let you know that the bank roof looks great. I suppose that many of our visitors will never truly appreciate the roof's authenticity and the level of effort that went into creating it, but some will and we in the research and collections department certainly do. Also, thanks to you and your crew for being so cooperative during our little photo-shoot, and also during the many interruptions of my visits.*

*Testimonial - Ed Hood, Research Historian Architecture and Materials Life Old Sturbridge Village*

## **ILLEGAL ALIENS TAKING ROOFING JOBS?**

All too often, a salesperson bids someone's roof and when the crew shows up to do their job, it's hard to find an english-speaking worker - except for perhaps the foreman.

Recently, "stormchasers" came through the upstate New York area after a hailstorm from Alabama, Texas, Mississippi and elsewhere, bringing their "trunkslammer" crews to do the work. After catching up with their jobs, they headed back south leaving homeowners wondering would they come back if a problem develops.

***“These fly-by-night contractors may be hiring illegals to avoid the required payroll taxes and insurances, creating an unfair competitive advantage”***

Roofs applied in the northeast must be applied with the harsh winters in mind. Not only are these out-of-state roofers taking jobs from local contractors, they are using workers unskilled in the application of roofing for northern climates.

These fly-by-night contractors may be hiring illegals to avoid the required payroll taxes and insurances, creating an unfair competitive advantage.

One local roofer had a van full of Mexican illegals picked up with only a Mexican drivers license for identification.

Bottom Line: It's your roof, home and community; you get to decide what type of contractor you will hire to protect it.

## Built-In Gutters Continued.....

After generations, these gutters were invariably neglected, not kept painted while unskilled homeowners or contractors would coat them with tar for a short term fix. Not understanding how to do the sheetmetal restoration, roofers would span the gutters with plywood and shingle over. Some companies try to reline them with a rubber membrane and as the rubber dries out it shrinks, eliminating the trough in areas causing ponding or overflowing of water.

At Vanguard, we restore the gutters completely, replacing rotted supports or rebuilding the total cornice if necessary.

Soldering of tin and copper is fast becoming a lost art, but necessary to correctly restore a tin or copper gutter lining.

At Vanguard, we take pride in the craftsmanship of forming and soldering of built-in gutters, to restore them to their original beauty and function in protecting the home exterior.

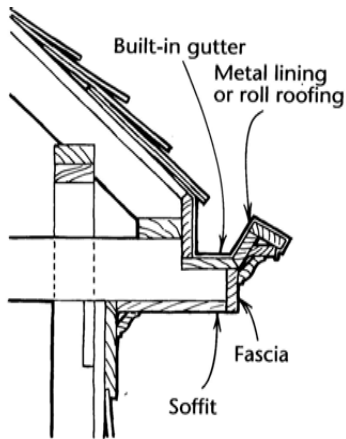

\* Courtesy of The Taunton Press, Inc.  
(c) 1998. "Renovating Old Houses"  
by George Nash.

## DID YOU KNOW?

Tinplate or "terne" was first manufactured in Bohemia about the thirteenth century, but Major John Hanbury of Pontypool, Great Britain, established the first permanent plant for the production of tinplate in 1720.



[Staats checks alignment and pitch for a built-in gutter/terne roof restoration.]

## Terne & Copper Continued (2).....

Unfortunately, many of these grand low-pitched roofs have been re-roofed with EPDM rubber, eliminating built-in gutters and nailing termination bar and rubber right over the adjoining siding!

Most roofing companies lack the expertise of installing terne roofs and have little regard and appreciation for the carpentry work that is needed to make a proper restoration.

At Vanguard Roofing and Construction, we specialize in all phases of a restoration project to bring back the original beauty and function of a terne or copper roof.

- Jim Staats

FOR MORE INFORMATION ON  
TERNE ROOFING SEE:  
[www.follansbeeroofing.com](http://www.follansbeeroofing.com)

87 Murray Ave Delmar, 1 Coventry Rd Glenmont, 61 Thornton St Albany, 9 Glendale Ave Delmar, 18 Ruppert Rd Selkirk, 433 Bullock Rd Slingerlands, 689 Delaware Ave Delmar, 11 Laurel Dr Elsmere, 75 Fisher Blvd Slingerlands, 57 Brockley Dr Delmar, Macedonia Baptist Church 172 Allen St Albany, 211 Van Weis Pt Glenmont, 65 Lake St Tupper Lake, 72 Hawthorne Ave Albany, 71 Middlesex Dr Slingerlands, 24 Linda Ct Elsmere, 75 Osborne Rd Albany, 141 Barent Winnie Rd Selkirk, 13 Beacon Rd Glenmont, 30 Bellwood Way Castleton, 11 Brookside Dr Elsmere, 39 Willowbrook Ave South Bethlehem, 8 Sandhurst Slingerlands, 10 Sandhurst Slingerlands, 65 Altamont Rd Voorheesville, 6 Prospect St Coxsackie, 26 Partridge Rd Delmar, 134 Kent St Albany, 35 Roweland Ave Delmar, 150 Adams Pl Delmar, 20 McCormack Rd Slingerlands, 85 Hawthorne Ave Albany, 288 Van Weis Pt Glenmont, 117 Rosemont St Albany, 21 Pineview Ave Delmar, 4 Glendale Delmar, 68 Maple Ave Troy, 214 Winnie Rd Delmar, 26 Elliot Ave Albany, 11 Carriage Rd Delmar, United Methodist Church 5th Ave & Henning Rd Saratoga Springs, 17 Bedell Ave Elsmere, 47 Kenaware Ave Delmar, 119 Winnie Rd Delmar, 25 Wisconsin Ave Delmar, 96 Hawthorne Ave Albany, 5 Bailey Ave Delmar, 802 Washington Ave Albany, 248 Elm Ave Delmar, 128 Melrose Ave Albany, 481 Huron Rd Delmar, 576 CR 312 Clarksville, 479 Huron Rd Delmar, 83 Hawthorne Ave Albany, 19 Orchard St Delmar, 469 Woodlawn Ave Albany, 182 South Westchester Dr Delmar, 14 Pineview Ave Delmar, 17 Lyons Ave Menands, 160 S Pine Albany, 11 Burhans Pl Delmar, 43 Harris Ave Albany, 41 Davis Ave Albany, 9 Harrison Ave Elsmere 39 Davis Ave Albany, 9 Albion St Albany, 13 Chesnut Rd Delmar, 1327 New Scotland Rd Slingerlands, Upper Ely St Coxsackie, 9 McConnell Ave Ravena, 51 Central Ave Ravena, 58 Meadowland St Delmar, 485 Huron Rd Delmar, 12 Fernwood Dr Loudonville, Kenwood Convent of the Sacred Heart 799 S Pearl St Albany, 10 Fernbank Ave Delmar, 14 Aspinwall Rd Loudonville, 544 Provi-  
dence St Albany, 1406 Rt 143  
Coeymans Hollow, 64 Maple Ave Voorheesville, 968 New Scotland Rd  
Albany St Kinderhook, 25 Robinhood St  
Albany, 51 Willowbrook Ave South Bethlehem,  
Hill Rd N Loudonville, 576 Rt 20 New  
Winnie Ave Delmar, 174 Adams St  
Marlboro Rd Delmar, 48 Douglas Rd  
Westchester Delmar, 395 Loudon Rd  
Route 22 Hillsdale, 314 Osborne Rd  
203 Homesdale Albany, 1 Snowden Ave  
Slingerlands, South Bethlehem United  
Funeral Homes Greenville, 560 South  
3 Wedgewood Ln Voorheesville, 10  
East Selkirk, 78 Church Hill Rd  
Elmgrove Ave Troy, 86 Sharptown Rd  
Slingerlands, 225 S Manning Blvd  
Rt 9 Livingston, 48 Dove St Albany, 15  
Carroll Ter Albany, 1742 Crescent Rd Rexford, 22 Nathaniel Blvd Delmar, 16 St Clair Dr Delmar, 2 Oakwood Pl  
Delmar, 24 Marlboro Rd Delmar, 59 Brockley Dr Delmar, 243 Murray Ave Delmar, 255 Hackett Blvd Albany, 9  
Pineridge Pl Delmar, 1 Taylor Ter Delmar, 26 Sycamore St Albany, 605 Delaware Ave Delmar, 125 Mansion St  
Coxsackie, 11 Groesbeck Pl Delmar, 13 Hawthorne Ave Delmar, 26 Clayton Pl Albany, 2 Bradford Pl Slingerlands, 39  
Hurlbut St Albany, 33 Herrick Ave Delmar, 29 Harris Ave Ravena, 19 Elsmere Ave Delmar, 14 Fernbank Delmar, 1  
McGee Dr Glenmont, 679 Delaware Ave Albany, Old Sturbridge Village Bank, Sturbridge, MA, Bollinger Mill State  
Historic Site, Burfordville, MO, 385 Snyders Lake Rd Wynantskill, 182 Martins Hill Rd Ravena, 1906 Evva Dr  
Schenectady, Mt. Calvary Baptist Church Albany, #821 Route 9W Glenmont, 50 Hudson St Kinderhook, 203 Homes  
Dale Albany, 64 Maple Ave Voorheesville, 225 South Manning Blvd Albany, 2 S Helderberg Pkwy Slingerlands, 10  
Lafayette Ave Coxsackie, 92 Marshall Rd Ravena, 5482 Rt 67 East Durham, 277 Rowe Rd Selkirk, 41 Douglas Rd  
Delmar, 82 Church Hill Rd Waterford, 3 Wedgewood Ln Voorheesville, 9 West Hawley Coxsackie, Rt 385 Coxsackie,  
Rt 144 Selkirk, 228 Van Weis Pt Rd Glenmont, 6 Elmhurst Ave, 14 Fernbank Ave Delmar, 31 Old School House Rd  
Selkirk, 17 Sunset Dr Selkirk, 182 Martins Hill Rd Ravena, 1990 Evva Dr Schenectady, 34 County Rt 1 Westerlo, 20  
Shad Way Voorheesville, Rt 396 Bridge St South Bethlehem, 150 Pawling Ave Troy, 171 Milner Ave Albany, 2341 Rt  
23 Hillsdale, 112 Cardinal Ave Albany, 30 Maple Ave Slingerlands, 116 Sanders Ave Scotia, 33 Maple Ave  
Slingerlands, 40 Thorndale Rd Slingerlands, Christ Episcopal Church Rt 32 Greenville, 48 Dove St Albany, 15 Caroll  
Terr Albany, 663 Western Ave Albany, 128 Melrose Ave Albany, 22 Nathaniel Blvd Delmar, 23 Smith Ave Selkirk, 66  
Church Hill Rd Waterford, 28 Couse Lane Slingerlands, 109 Main St Ravena, 560 South Albany Rd Selkirk, 19  
Colonial Albany, 968 New Scotland Ave Albany, 27 Wedgewood Ln Voorheesville, 929 Rt 9w Selkirk, 1742 Crescent  
Rd Rexford, 193 S Westchester Dr Delmar, 769 Buck Hill Rd Arlington, VT, 2022 Maple Ave Charlton.

**PARTIAL  
LIST OF  
COMPLETED  
ROOFS AND  
RESTORATION  
WORK**